

Part Number: PT276-34071

Kit Contents

Item #	Quantity Reqd.	Description
1	1	Spare Tire Lock
2	1	Key
3	1	Order Form
4	1	Installation Instruction Sheet
5	1	Customer Notice Card
6	1	Envelope
7	1	ID Card

Hardware Bag Contents

Item #	Quantity Reqd.	Description
1		
2		
3		

Additional Items Required For Installation

Item #	Quantity Reqd.	Description
1		
2		
3		

Conflicts

None

Recommended Tools

Personal & Vehicle Protection	Notes
Special Tools	Notes
Installation Tools	Notes
Jack Handle	P/N - 09150-0C010
Extension Rods	P/N - 09114-0C030 P/N - 09115-0C030
Special Chemicals	Notes

NOTE: Part number of this accessory may not be the same as the part number shown.

General Applicability

All Tundra

Recommended Sequence of Application

Item #	Accessory
1	
2	
3	

*Mandatory

Vehicle Service Parts (may be required for reassembly)

Item #	Quantity Reqd.	Description
1		
2		
3		

Legend



STOP: Damage to the vehicle may occur. Do not proceed until process has been complied with.



OPERATOR SAFETY: Use caution to avoid risk of injury.



CAUTION: A process that must be carefully observed in order to reduce the risk of damage to the accessory/vehicle and to ensure a quality installation.



TOOLS & EQUIPMENT: Used in Figures calls out the specific tools and equipment recommended for this process.



REVISION MARK: This mark highlights a change in installation with respect to previous issue.



SAFETY TORQUE: This mark indicates that torque is related to safety.

Procedure

Care must be taken when installing this accessory to ensure damage does not occur to the vehicle. The installation of this accessory should follow approved guidelines to ensure a quality installation.

These guidelines can be found in the "Accessory Installation Practices" document.

This document covers such items as:-

- Vehicle Protection (use of covers and blankets, cleaning chemicals, etc.).
- Safety (eye protection, rechecking torque procedure, etc.).
- Vehicle Disassembly/Reassembly (panel removal, part storage, etc.).
- Electrical Component Disassembly/Reassembly (battery disconnection, connector removal, etc.).

Please see your Toyota dealer for a copy of this document.

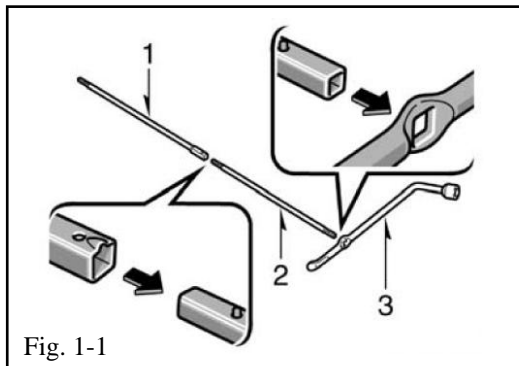



1. Assemble Jack Handle and Lower Spare Tire.

- (a) Remove the tool bag from the storage location (Fig. 3-1 on page 3)
- (b) Assemble the jack handle (3) and extensions rods (1 & 2) (Fig. 1-1).

 (c) Insert the square end of the extension rod through the access hole in the bumper and into the lowering screw (Fig. 1-2).

 (d) Turn counterclockwise making sure the jack handle remains firmly fitted to the extension rods.

 (e) Lower the tire partially from the vehicle to a suitable height allowing access to the lowering screw.

 (1) Ensure the wheel is safely supported in that position to prevent the spare tire from swaying during the spare tire lock installation.

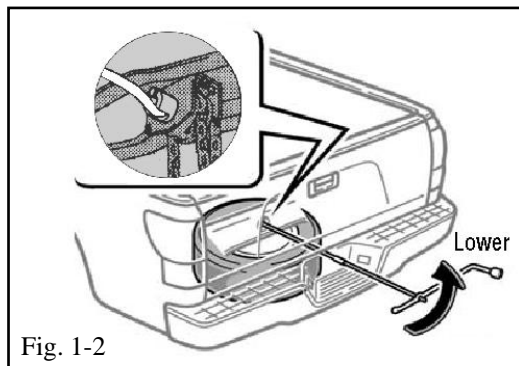

2. Spare Tire Lock Installation.

- (a) Install the spare tire lock assembly into the lowering screw (Fig. 2-1).

(1) Line up the cross pin on the spare tire lock with the slot on the lowering screw. Press the spare tire lock in place until fully seated into the bottom of the lowering screw.

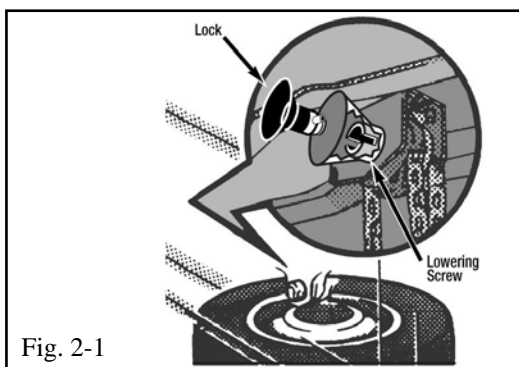

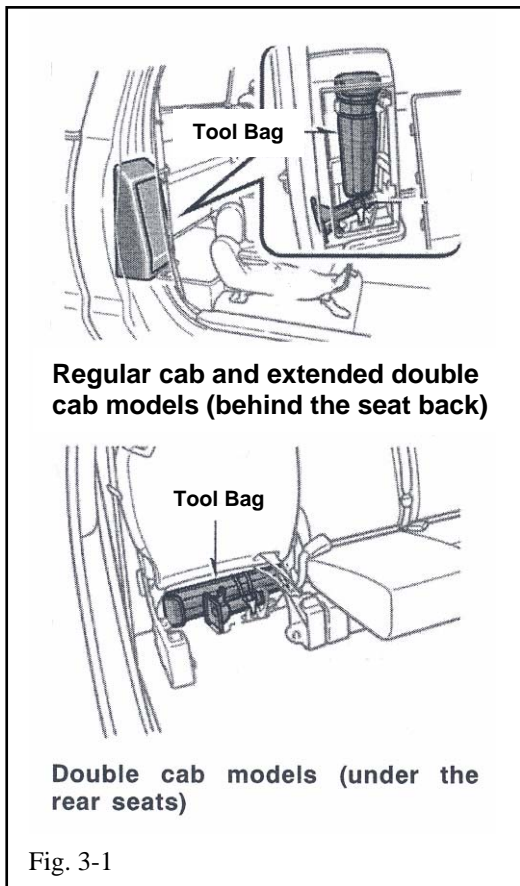
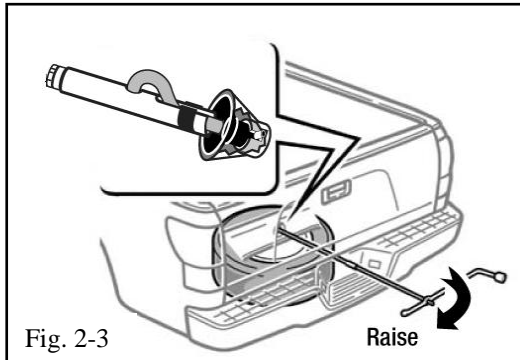
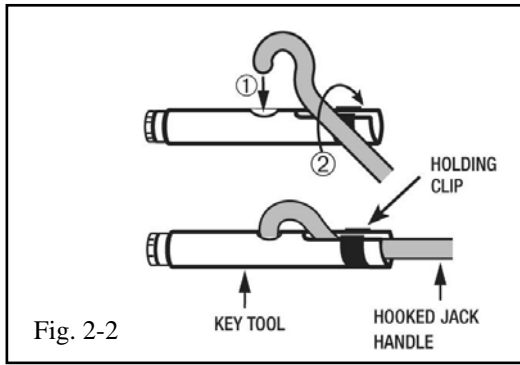

(b) Assemble the key assembly onto the hooked extension rod (Fig. 2-2).

 (c) Insert the extension rod with key through the access hole in the rear bumper (Fig. 2-3).

 (d) Rotate key in the lock assembly until the lock and key patterns engage.

 (e) Turn the jack handle clockwise making sure that the jack handle remains firmly fitted to the extension rod raising the tire until it is stowed in its original position.

3. Installation Completion

(a) Disassemble the extension rod and key.

(b) Place the key into the tool bag and stow with jack in the vehicle storage area (Fig. 3-1).

(c) Place the ID card, order form, customer notice card and instruction sheet in the McGard envelope.

(d) Place the envelope into the glove compartment.

TOYOTA TUNDRA 2010 - SPARE TIRE LOCK

Checklist - these points **MUST** be checked to ensure a quality installation.

Check: _____

Accessory Function Checks

- Spare tire lock has been properly installed

- Spare tire lock key storage

- Customer Documents

Look For: _____

Verify spare tire lock is fully seated in the bottom of the lowering screw.

Key is stowed with the jack handle and extensions and placed in the tool bag.

McGard envelope with documents are placed in the glove box.

Vehicle Function Checks

- Spare Tire

- Tool Bag

Spare tire is stowed in its original position.

Tool Bag is stored and secured in the original position.